

VL STUDIO WALL

The fixture emits a glare-free, diffused light. The triple-layered opal glass provides pleasant and uniform illumination of the area around the fixture. The lampshade can be tilted 90 degrees to the right or left, which allows for flexible light distribution.



Vilhelm Lauritzen

Vilhelm Lauritzen (1894–1984) is one of the most significant architects in the history of Denmark; he was the trail-blazing figurehead of Danish functionalism. A number of his buildings – Nørrebro Theatre (1931–32), Daells Varehus department store (1928–35), Radihuset (1936–41) and the first airport built in Kastrup (1937–39) – represented the concentrated essence of contemporary life.



Product info

Information

The adjustable lampshade can be tilted 90 degrees to the right or left. The untreated brass will change over time and develop a patina.

Mounting

Surface: Mounted directly to finished surface over a 4" octagonal junction-box. Glass can be unscrewed to change the light source. No switch is on the luminaire; remote switch is required.

Finish

matte black, wet painted or brushed brass with fine hairlines. White opal glass, glossy. Clear lacquered brass.

Materials

Glass: Hand-blown, triple-layered opal, glossy. Housing: Deep-drawn aluminum or brass. Wall box: Die-cast aluminum or forged brass. Please note that the untreated brass will patinate.

Sizes and weight

Width x Height x Length (in.) | 5.9 x 5.9 x 7.9 Max 2.9 lbs

Compliance

cULus, Dry location.

Light source

1x5W G9

Information

The adjustable lampshade can be tilted 90 degrees to the right or left. The untreated brass will change over time and develop a patina.

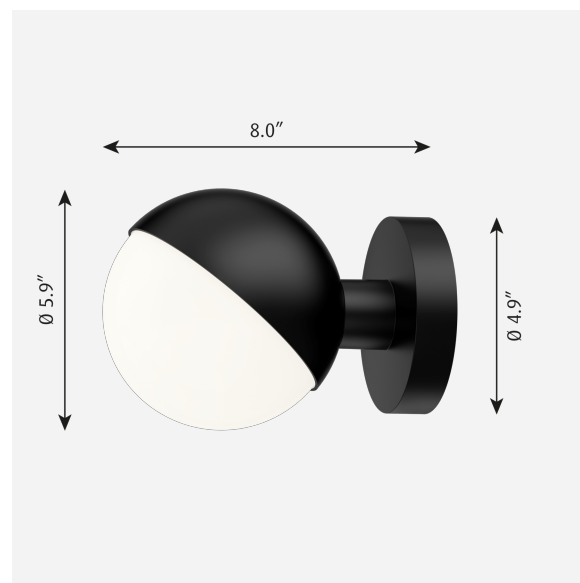

Related products

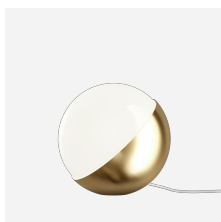

VL Studio Table/Floor

Product variants

Dimension	Color	Light source	Voltage frequency
5.9 IN	<ul style="list-style-type: none"> Black Lacquered brass 	1x5W G9	120V

Light description

The fixture emits a glare-free, diffused light. The triple-layered opal glass provides pleasant and uniform illumination of the area around the fixture. The lampshade can be tilted 90 degrees to the right or left, which allows for flexible light distribution.

Design

Vilhelm Lauritzen

Material

Glass: Hand-blown, triple-layered opal, glossy.

Housing: Deep-drawn aluminum or brass.

Wall box: Die-cast aluminum or forged brass. Please note that the untreated brass will patinate. Surface: Mounted directly to finished surface over a 4" octagonal junction-box. Glass can be unscrewed to change the light source. No switch is on the luminaire; remote switch is required.

Weight

Min: 1.874 lbs Max: 2.866 lbs

Dimensions

5.9 IN

Finish

Black, Lacquered brass

Voltage

120V

Light distribution diagrams

Cartesian

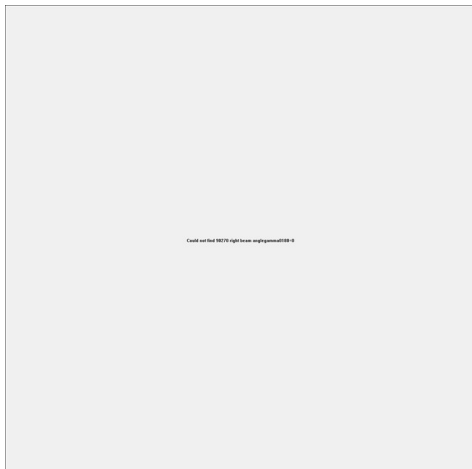

Isolux

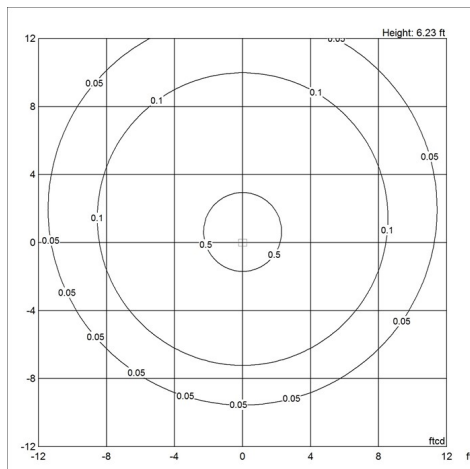

Polar

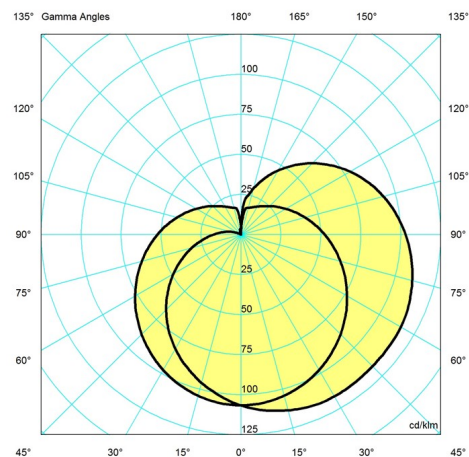

Spare parts & accessories

Product

VL Studio Table/Wall, White grommet
 VL Studio Ø150 Wall glass
 VL Studio Table/Wall, Black grommet
 VL Studio Ø150 Wall black pinol screw
 VL STUDIO 150 WALL PINOL SCREW BRASS

Variant number

5744167877
 5743151868
 5744167880
 5743151871
 5743151884