

VL STUDIO TABLE/FLOOR

The fixture emits a diffused, glare-free light. The triple-layered opal glass provides a comfortable light distribution and radiates a pleasantly delicate glow to its surroundings.

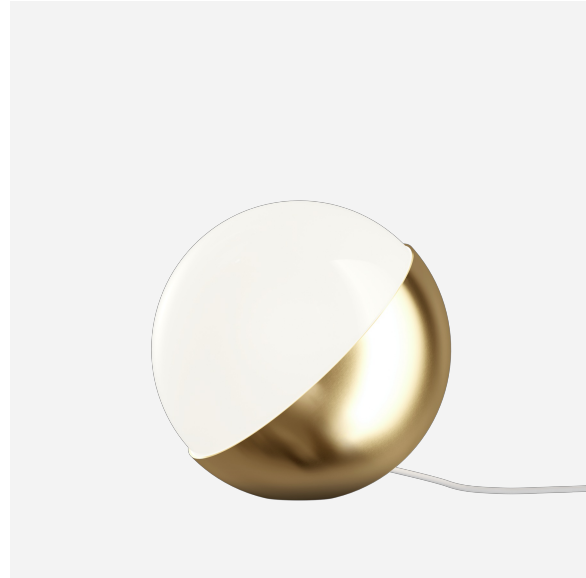

Vilhelm Lauritzen

Vilhelm Lauritzen (1894–1984) is one of the most significant architects in the history of Denmark; he was the trail-blazing figurehead of Danish functionalism. A number of his buildings – Nørrebro Theatre (1931–32), Daells Varehus department store (1928–35), Radihuset (1936–41) and the first airport built in Kastrup (1937–39) – represented the concentrated essence of contemporary life.



Product info

Information

The untreated brass will change over time and develop a patina.

Mounting

Glass shade can be removed to change the lamp. 8.2' Cord. Black for black version and white on brass versions. Ø150: On/off switch on cable. Ø250 and Ø320: Electronic dimmer switch (requires dimmable lamp).

Finish

Matte-black, wet-painted; or brushed brass with fine hairlines. White opal glass, glossy. Clear-lacquered brass.

Materials

Glass: Hand-blown, opal, triple-layered, glossy. Housing: Deep-drawn aluminum or brass.

Sizes and weight

Width x Height x Length (in.) | 9.8 x 9.6 x 9.8 Max 8.4 lbs | 5.9 x 5.7 x 5.9 Max 2.9 lbs | 12.6 x 12.2 x 12.6 Max 17.4 lbs

Compliance

cULus, Dry location.

Light source

1x15W A-19/medium

Information

The untreated brass will change over time and develop a patina.

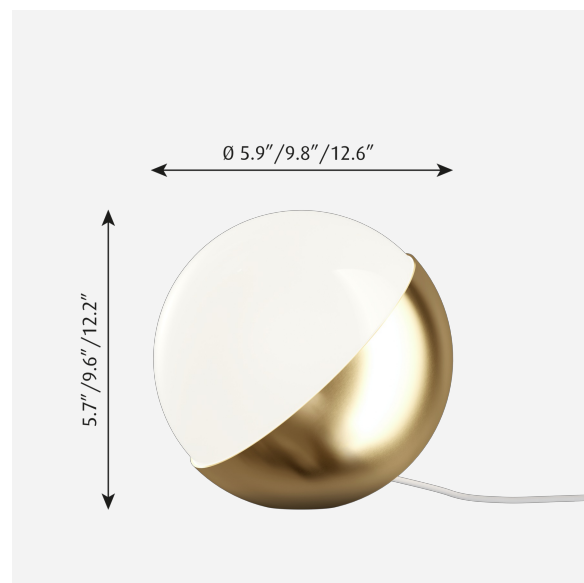

Related products

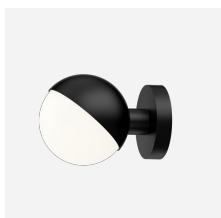

VL Studio Wall

Product variants

Dimension	Color	Cable type	Light source	Voltage frequency	Switch
12.6 IN	● Black	Black cord	-	-	With dimmer
5.9 IN	● Lacquered brass	White cord	1x15W A-19/medium	120V	With switch
9.8 IN			1x5W G9		

Light description

The fixture emits a diffused, glare-free light. The triple-layered opal glass provides a comfortable light distribution and radiates a pleasantly delicate glow to its surroundings.

Design

Vilhelm Lauritzen

Material

Glass: Hand-blown, opal, triple-layered, glossy.

Housing: Deep-drawn aluminum or brass. Cable type: Black for black version and white on brass versions.

Cable length: 8.2 ft. In-line switch.

Ø150: On/off switch. Ø250 and Ø320: Electronic dimmer switch (requires dimmable lamp). Glass shade can be removed to change the lamp.

Weight

Min: 14.661 lbs Max: 8.378 lbs

Dimensions

12.6 IN, 5.9 IN, 9.8 IN

Finish

Black, Lacquered brass

Voltage

120V

Light distribution diagrams

Cartesian

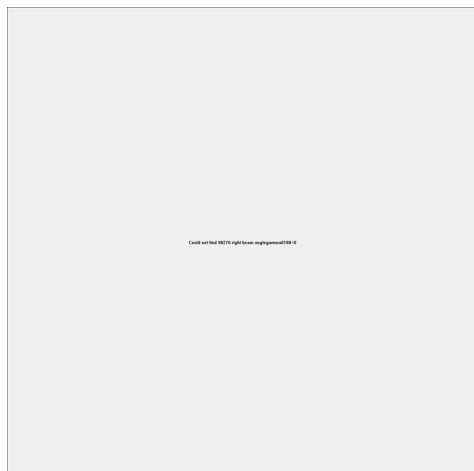

Isolux

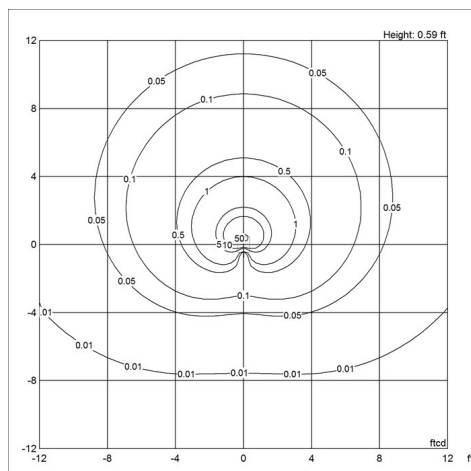

Polar

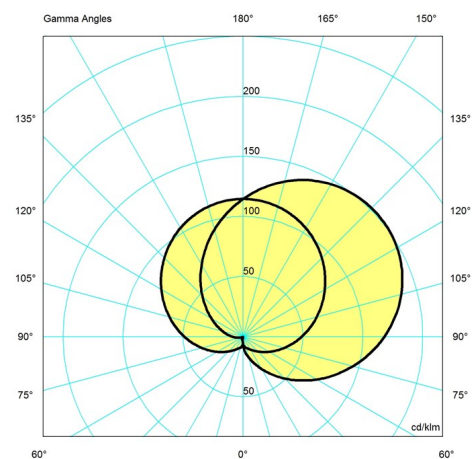

Spare parts & accessories

Product

VL Studio Ø320 Table glass
 VL Studio Table/Wall, White grommet
 VL Studio Ø150 Wall glass
 VL Studio Ø250 Table glass
 VL Studio Table/Wall, Black grommet

Variant number

5744167864
 5744167877
 5743151868
 5744167851
 5744167880