

PH 5

The fixture provides a comfortable, glare-free light based on the principle of Poul Henningsen's reflective three-shade system, which directs the majority of the light downward. It emits a lateral light as well as illuminating itself, providing a soft radiance from within its core. The lower shade is fitted with a frosted-glass diffuser to ensure that the downwardly directed light is 100% glare-free.



Poul Henningsen

Poul Henningsen was born in Copenhagen by the famous Danish writer Agnes Henningsen. He never graduated as an architect, but studied at The Technical School at Frederiksberg, Denmark from 1911-14, and then at Technical College in Copenhagen from 1914-17.



Restaurant
Madsen



Product info

Environmental Product Specification

This product is compliant with the requirements contained in the European Directives, RoHS Directive 2011/65 and 2015/863. This product is designed so that 100% of the product can be disassembled and reused.

Information

Color of anti-glare disc: Blue: White Classic, Monochrome Blue and Hues of Orange. Green: Hues of Red and Hues of Rose. Red: Hues of Green and Hues of Blue. Rose: Pastel Blue Rose Peach, Hues of Grey and White Modern. Peach: Pastel Oyster Blue Rose. Raw: Raw. Same color/material as main shade on Monochrome and Metal variants. Color of struts: Purple: White Classic. Bronze colored: White Modern and Hues of colors. White: Copper, Brass and Pastels. Raw: Raw. Same color as main shade on Monochrome variants. Cable and canopy: Monochrome Black: Black cable and canopy. All others: White cable and canopy. Please note that the copper and brass surface is untreated. This means that the surface will change over time and develop a patina. This process may have already begun when the product is delivered.

Mounting

Canopy and cord: Black for Monochrome Black, White for all other colors. Cord type: 3-conductor, 18 AWG cloth-covered power cord. Cord length: 12 feet.

Finish

Matt powder coated or Matt wet painted. Powder coated: White Classic, White Modern and Metal finishes. Wet painted: Monochromes, Pastels and Hues Of finishes. Raw: The metal surface is raw after being stripped of previous paint. As a result of the stripping process, the finish of the aluminum surface naturally varies between darker and lighter tones. The lower shade is made of steel and has a different surface that may encounter occasional rust. Please note that the copper and brass surface is untreated. This means that the surface will change over time and develop a patina.

Materials

Lower shade: Spun steel. Other shades and anti-glare disc: Spun aluminium, spun copper or spun brass. Struts: Rolled aluminium. Diffuser: Frosted glass.

Sizes and weight

Width x Height x Length (in.) | 19.5 x 10.5 x 19.5 Max 8.0 lbs

Compliance

cULus, Damp location.

Specification notes

For the Raw version please notice the shades may appear with small irregularities, crookedness, and dents. Please note that the metal surface is treated with a dry lubricant to prevent further patination. The lower steel shade will corrode over time unless it is treated further. If preferred, applying a dry lubricant every now and then will help maintain the original raw- metal finish.

Light source

1x22W A-21/medium

Information

Color of anti-glare disc:

Blue: White Classic, Monochrome Blue and Hues of Orange.

Green: Hues of Red and Hues of Rose.

Red: Hues of Green and Hues of Blue.

Rose: Pastel Blue Rose Peach, Hues of Grey and White Modern.

Peach: Pastel Oyster Blue Rose.

Raw: Raw.

Same color/material as main shade on Monochrome and Metal variants.

Color of struts:

Purple: White Classic.

Bronze colored: White Modern and Hues of colors.

White: Copper, Brass and Pastels.

Raw: Raw.

Same color as main shade on Monochrome variants.

Cable and canopy:

Monochrome Black: Black cable and canopy.

All others: White cable and canopy.

Please note that the copper and brass surface is untreated. This means that the surface will change over time and develop a patina. This process may have already begun when the product is delivered.



Related products



PH 5 Mini



PH 5 Anniversary Edition

Product variants

Color	Cable type	Light source	Voltage frequency
<input checked="" type="radio"/> Brass	Black fabric cord	1x22W A-21/medium	120V
<input type="radio"/> Copper	White fabric cord		
<input type="radio"/> Hues of blue			
<input type="radio"/> Hues of green			
<input type="radio"/> Hues of grey			
<input type="radio"/> Hues of orange			
<input type="radio"/> Hues of red			
<input type="radio"/> Hues of rose			
<input type="radio"/> Monochrome black			
<input type="radio"/> Monochrome blue			
<input type="radio"/> Monochrome oyster grey			
<input type="radio"/> Monochrome pale rose			
<input type="radio"/> Monochrome white			
<input type="radio"/> Pastels blue rose peach			
<input type="radio"/> Pastels oyster blue rose			
<input type="radio"/> White classic			
<input type="radio"/> White modern			

Product description

Pendant of iconic design. Poul Henningsen developed the PH 5 in 1958 as a follow-up to his celebrated three-shade system. The fixture emits both downward and lateral light, thus illuminating itself. In the PH 5 Classic, a warmer tone of light is created by the inside red cone and a small blue reflector. The shades are aluminum with matte white finish on the lower surfaces, giving a soft and uniform light distribution. Available in two sizes with a wide variety of colors and materials. Copper and brass pendants are untreated and will patinate over time.

Mounting

Mounts onto a 4 inch octagonal outlet box. Canopy: Flat cone profile, 5.3 IN diameter x 1 IN tall, black for monochromatic black, white for all other finishes. Cord type: 3-conductor, 18 AWG fabric-covered power cord, black for monochromatic black, white for all other finishes. Cord length: 12 feet.

Light description

Spherical light distribution. The top trumpet shaped shade provides vertical illumination of the room. The three lower shades direct light downward. The curvature of the shades and their positions combined with a bottom frosted glass disk positioned inside the smallest shade limit viewing of the lamp to reduce glare. Provided with a medium base socket for the customer to provide their desired lamp.

Design

Poul Henningsen

Material

Shades: spun aluminum, 0.06 IN thick. Vertical struts: extruded aluminum sleeves over steel rods. Canopy is spun aluminum, 0.03 IN thick. Standard finish are matte surface powder coat with minimum 2 mils thickness in white. Wet painted colors on shade top surfaces and on sleeves.
Brass, Copper, Hues of blue, Hues of green, Hues of grey, Hues of orange, Hues of red, Hues of rose, Monochromatic black, Monochromatic blue, Monochromatic white, White classic, White modern

Weight

Min: 4.709 lbs Max: 7.972 lbs

Other functions

Longer cord lengths.

Finish

Brass, Copper, Hues of blue, Hues of green, Hues of grey, Hues of orange, Hues of red, Hues of rose, Monochrome black, Monochrome blue, Monochrome oyster grey, Monochrome pale rose, Monochrome white, Pastels blue rose peach, Pastels oyster blue rose, White classic, White modern

Voltage

120V

Light distribution diagrams

Cartesian

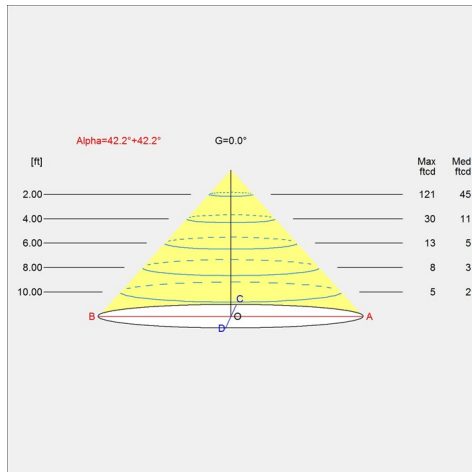

Isolux

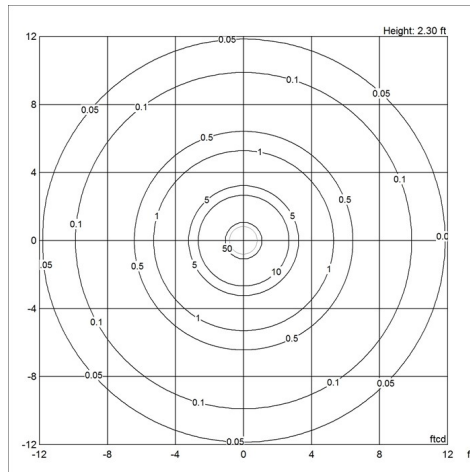

Polar

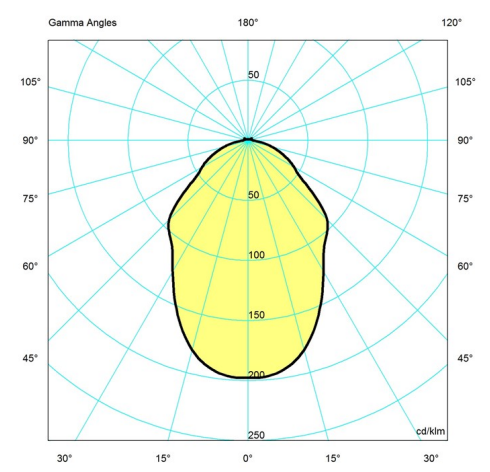

Spare parts & accessories

Product	Variant number
Canopy White 2-part tophat @	5749329034
Canopy Black 2-part tophat@	5749329021
Small canopy, white	S0771
Small canopy, black	10000018378
PH 5 glass disc	5741093300
PH 5 Bearing plate 10/56, t/standard susp.	5741480667
Extension nipple f/stand. suspen	5741480670
PH 5 Purple spacers	5741093407
PH 5 Bronze spacers	5741100235
PH 5 Alu spacers	5741100015
PH 5 White spacers	5741100248
PH 5 Monochrome White spacers	5741106093
PH 5 Monochrome Blue spacers	5741106103
PH 5 Monochrome Black spacers	5741106116
PH 5 electrical assembly	5741910988